

Wireless
Fiber Optic
Secure WAN
Remote Power
Ethernet Switches
IP over Coax & UTP
Mobile Surveillance



KBC Transmission & Remote Power Products



www.kbcnetworks.com

Rev2403NA



Transmission for a wide range of applications and markets

KBC industrial products are built to perform in non-conditioned environments, featuring wide operating temperatures and hardened casings.

Applications

- CCTV & surveillance
- Security
- Intelligent Transport Systems (ITS)
- Telemetry & SCADA
- Industrial control
- Access control systems
- Remote video, voice & data transmission
- Building & site management

Verticals

- Town & city center
- Transportation
- Critical National Infrastructure
- Petrochemical
- Power & utilities
- Government agency
- Military systems
- Counter-terror
- Homeland security
- Remote data
- Emergency services
- Commercial & retail
- Residential



KBC designs and delivers tried, tested and trusted transmission, remote power & mobile solutions for your application.



ThruLink: Industrial VPN for encrypted and secure WAN transmission

Transmits IP signals over any type of WAN/LAN
 Embedded 4G/LTE version for streaming secure live video from vehicles
 Supports meshed networks; flexible & scalable
 Supports FIPS, Blowfish, AES & Camellia encryption, up to 256 bit
 Auto-reconnects if the network connection fails, multiple failover.



Media Converters: maximum flexibility provided through multiple options

10/100/1000Mbps media converters, Single mode and multimode
 PoE & SFP options available
 Compact size, Industrial rating
 Mounting configurations include Wall, DIN Rail & 2U High Rack Chassis options



EoC/EoU – eCopper™ – a simple way to transmit Ethernet over Coax or UTP

1,4,8 and 16 Channel models
 Transmit up to 1,200 Feet PoE+
 Transmit up to 2,600 Feet PoE
 Current protection
 POC Management



Switches: Managed and Unmanaged, PoE, PoE+, PoE++, Daisy Chain & Ring Configuration

Feature Rich
 Reliable High Performance
 Rugged IP40 Design
 Easy to Configure
 Supports ERPS
 Wide range of industrial SFPs available



Wireless

WES4 & WES4HTG Point to Point, Point to Multi-Point and Omni-directional

- WES4HTG – gigabit wireless 650 Mbps directional throughput
- WES4 – standard 400 Mbps throughput – versatile and easy setup
- Feature rich enhanced firmware
- 25 years of secure, reliable no-dig solutions
- Simple to use kit packaging



Fiber Optic

A full line of Digital Standard and ASFOM fiber optic products

Digital Standard – building blocks for point to point video, audio and data transmission
 ASFOM – Application Specific Fiber Optic Modules – custom configurable for the most demanding applications
 Wide range of industrial SFPs available

Remote Power & Mobile Surveillance

A full range of solar, wind and remote power solutions including UPS, power kits, power supplies & accessories

- AL2/AL5 Off-Grid power
- UAL2/UAL5 Backup Power 24/7
- MSS Temporary Surveillance



Secure transmission over public networks

Encrypted transmission over the Internet, 3G/4G/LTE

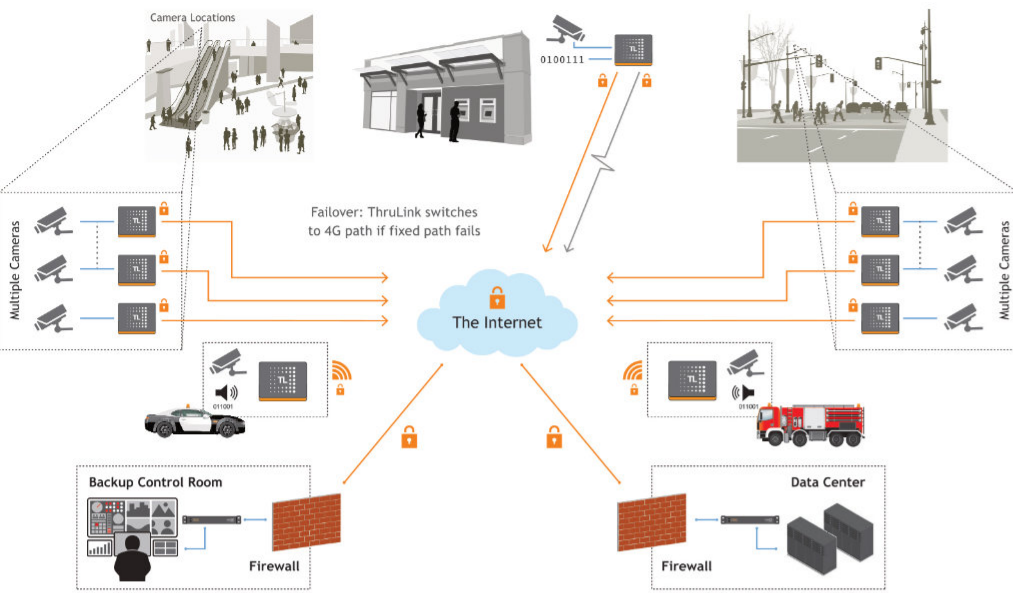

Wireless transmission

Point-to-point, point-to-multipoint, mesh & 4G/LTE

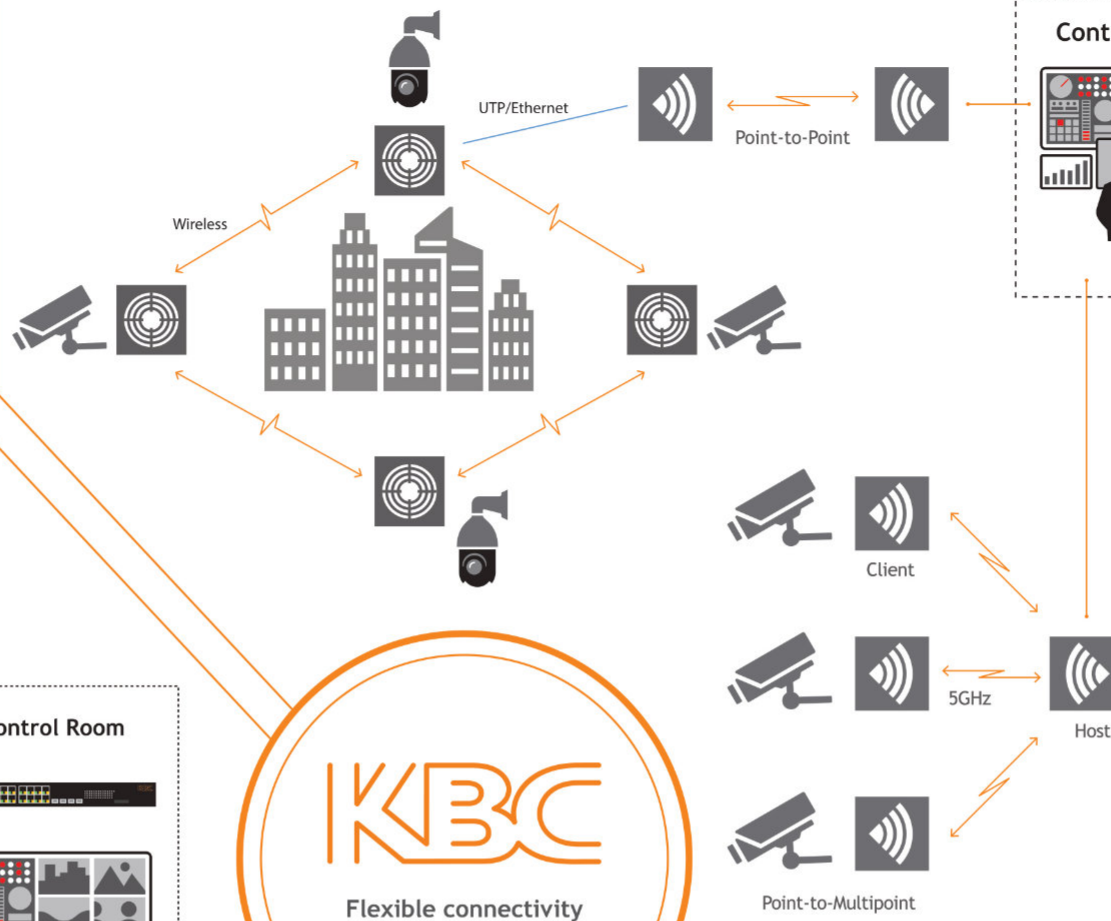

Remote power solutions

Solar, wind, UPS & PoE power kits

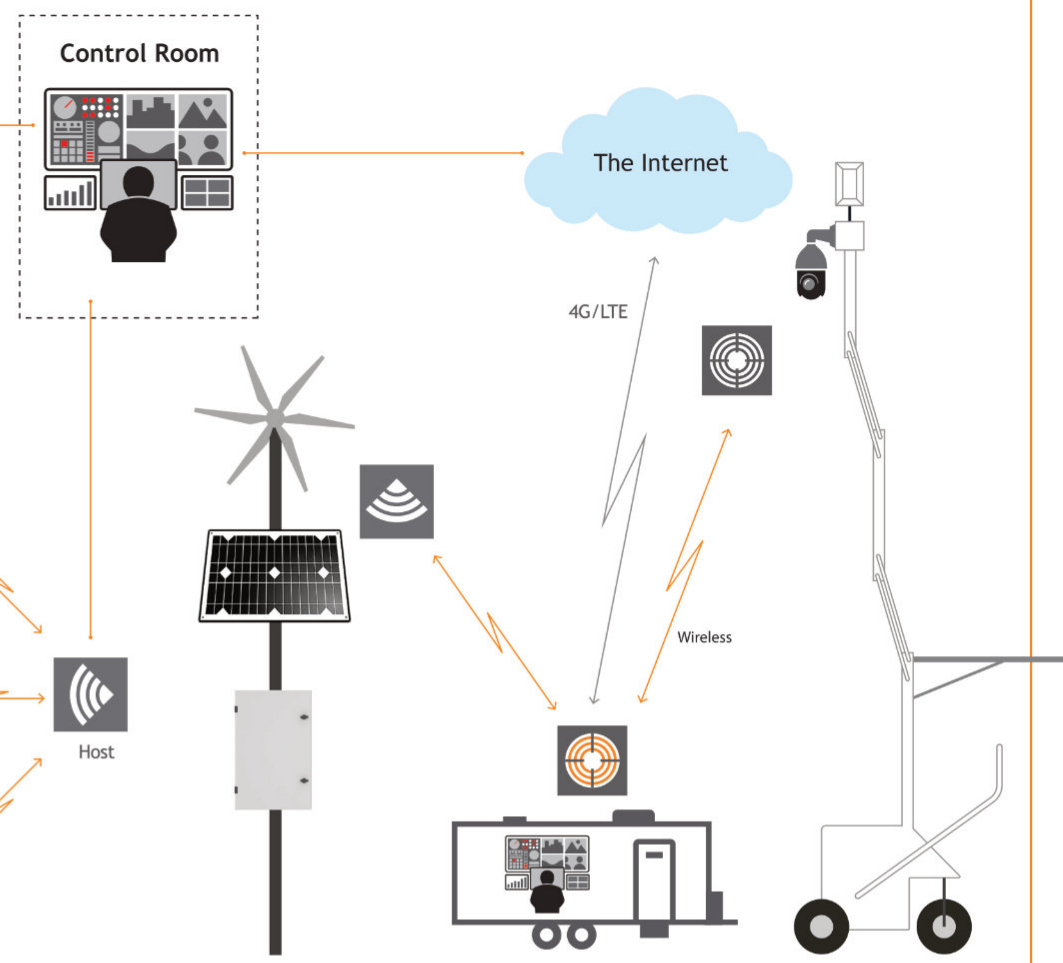

Control Room

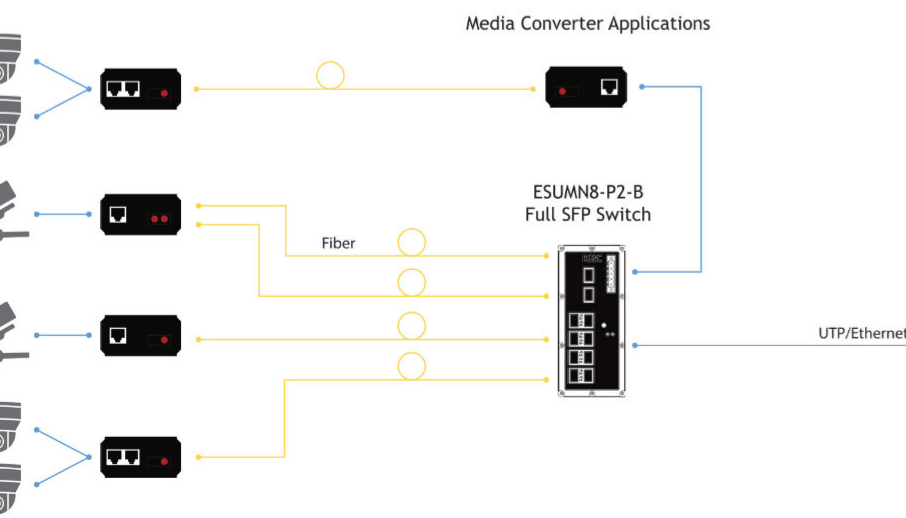
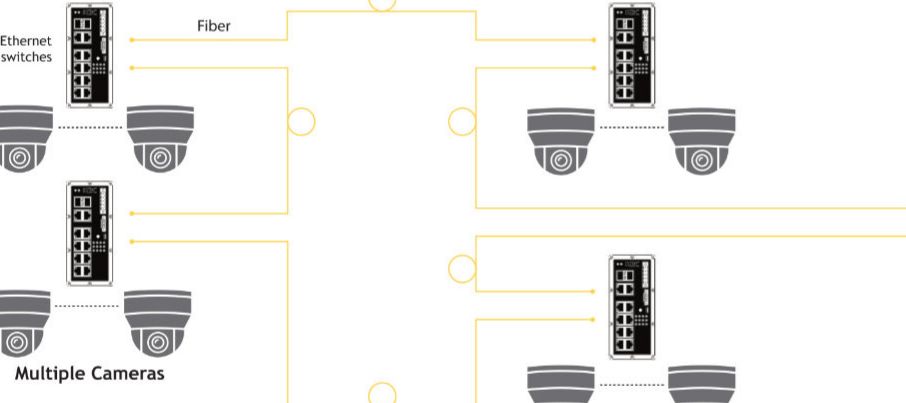
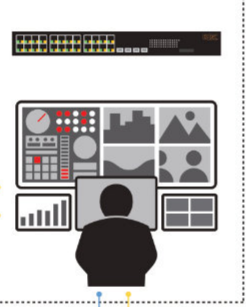

Ethernet over Coax (EoC) Applications

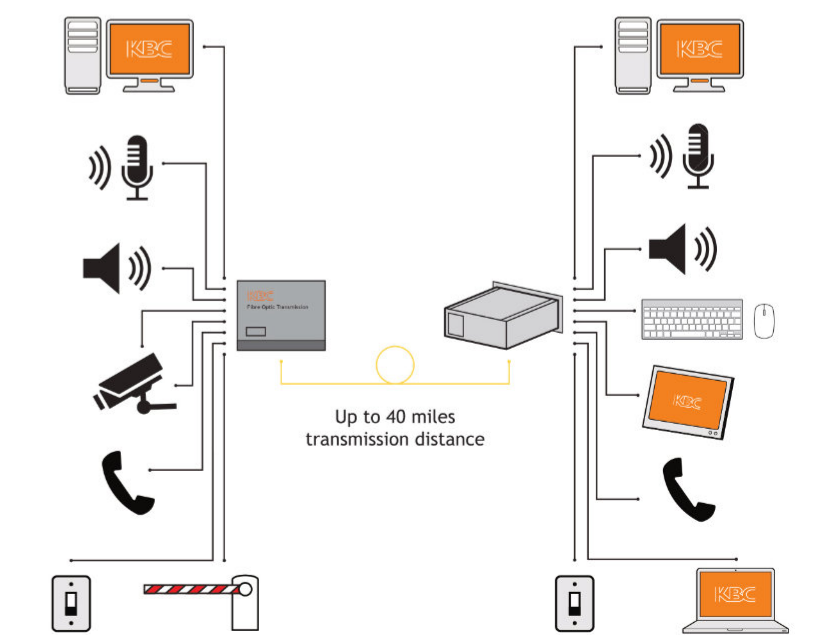
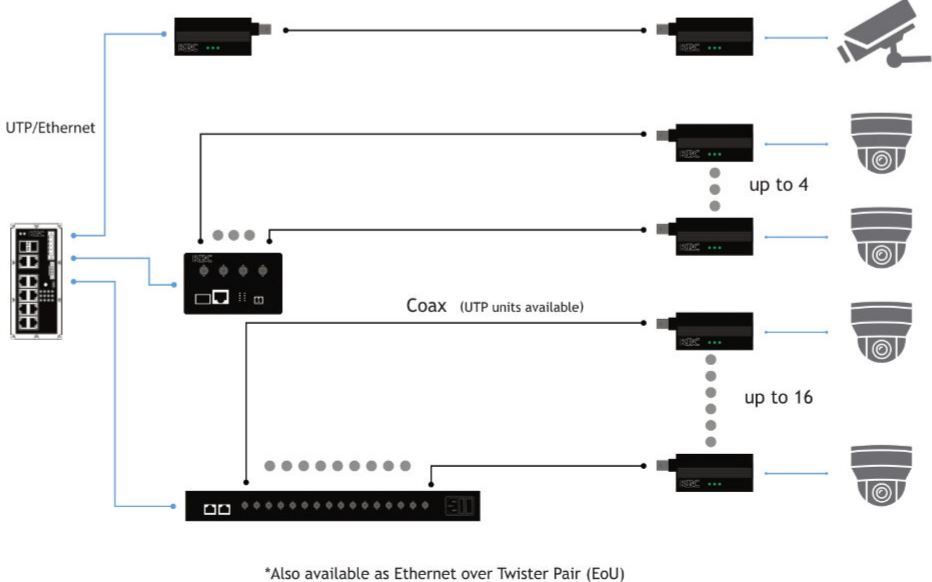

IP transmission

Ethernet switches, media converters, encoders & decoders, Ethernet extenders, SFPs, and 4G/LTE

Fiber optic transmission

Video, audio, data, contact closure, Ethernet, telephone, DVI, HD-SDI, 3G-SDI, USB

Integrity

Maintaining close, individual relationships with our customers and partners is our top priority. Everything we do as a company—and as individuals—is handled with complete integrity and respect.

Service

Superior service and support is a critical component of our business. We believe that successful network and system performance rely on accurate design and correct installation, so our technical and sales teams provide product support throughout the lifecycle of every project. Please contact us for customised pre-sales and technical support.

Quality

Reliability and high performance are at the core of our design, engineering and manufacturing processes. KBC is proud to offer products and services that go above and beyond recognized international standards.

More Products

We've included our major product groups in this brochure. For further detail about the complete range, please visit our website: www.kbcnetworks.com, or call your local representative

Better Installation

We spend time thinking about our products so you don't have to. KBC products are designed for straightforward set-up; simple analysis and minimal maintenance.

Greater Performance

Our products are built to perform in commercial and industrial environments. Our industrial ranges feature extended operating temperatures and industrially-hardened casings to withstand temperature extremes and the rigours of industrial and outdoor environments.

North America

KBC Networks
32409 Calle Perfecto
San Juan Capistrano, CA 92675
USA
Phone: +1 949 503 3470
Toll Free: +1 888 366 4276
info@kbcnetworks.com

Latin America & Caribbean

KBC Networks
Eclipse 2679A
Jardines Del Bosque
Guadalajara, Jalisco
Mexico 44520
Phone: +52 33 3148 3286
latam@kbcnetworks.com

Europe, Middle East & Africa

KBC Networks
7 Sylvan Court
Sylvan Way, Basildon
SS15 6TH
UK
Phone: +44 (0) 1553 600001
emea@kbcnetworks.com

Asia Pacific

KBC Networks
81 Nan Xijiang East Road
Room 919
Nanjing, Jiangsu 210019
China
Phone: +86 25 5882 1656
apacinfo@kbcnetworks.com